

Model

6AM-22A-GB40

(8 Vanes, Reversible)

Net wt. for standard configuration
104 lbs (46,8 kg)

FEATURES

- 40:1 gear reducer
- Base mounting
- Optional mountings and shaft locations available
- Muffler AC990 (not shown)

RECOMMENDED

- Filter AH106F
- Regulator AH107R
- Gauge AA806
- Lubricator AH108L
- Oil AD220 – 1 quart (.94 litres)
- Repair kit K281 (Air motor only)

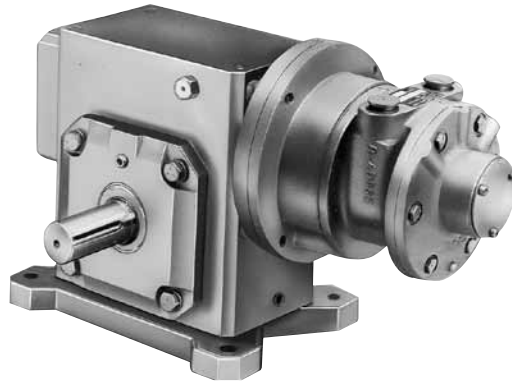

Max. allowable end thrust with 0 overhung load is 3552 lbs (1598,4 kg) at 30 rpm to 2154 lbs (969,3 kg) at 75 rpm. Max. overhung load on output shaft with 0 end thrust 2857 lbs (1285,7 kg).

Product Dimensions (inches, mm)

“B” Mounting (photo)
6AM-22A-GB40/6AM-22A-GF40
(standard shaft) (opposite shaft)

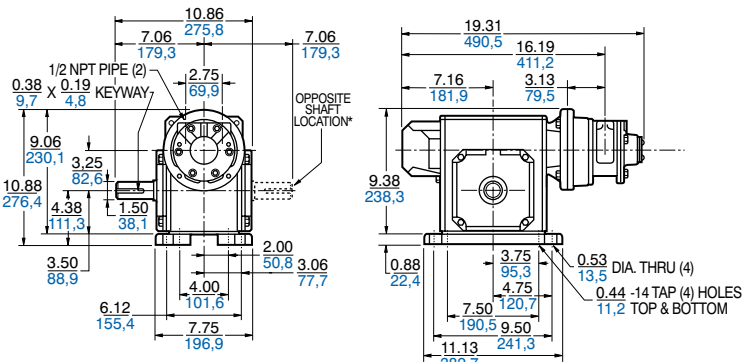

“C” Mounting
6AM-22A-GC40/6AM-22A-GG40
(standard shaft) (opposite shaft)

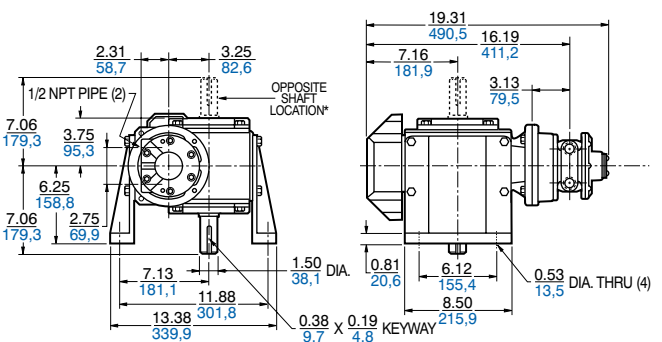

Output Power vs. Speed

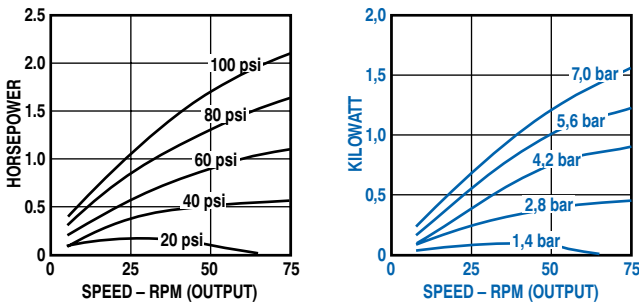

Torque vs. Speed

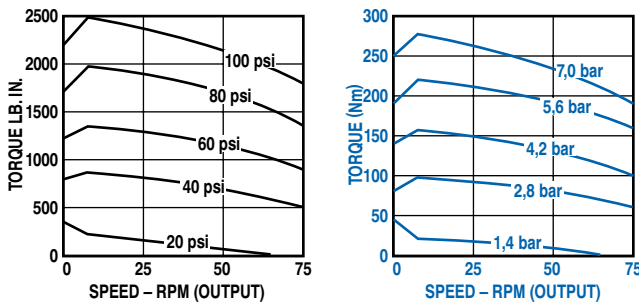

Air Consumption vs. Speed

